

# **2010: A TIME TO REVIEW THE PRODUCED WATER TREATMENT TECHNOLOGIES, A TIME TO LOOK FORWARD FOR NEW MANAGEMENT POLICIES**

Reza Mastouri\*

Islamic Azad University, Arak Branch  
Civil Engineering Faculty, Daneshgah Street  
Arak, Iran

(E-mail: [r-mastouri@iau-arak.ac.ir](mailto:r-mastouri@iau-arak.ac.ir))

Voice: 00 9861 3669218

Fax: 00 9821 8887 4123

Farhad Nadim

University of Connecticut, Department of Civil and Environmental Engineering, Storrs,  
Connecticut, USA

Nargess Kargari

Islamic Azad University, Takestan Branch  
Takestan, Qazvin

(E-mail: [n.kargari@tiau.ac.ir](mailto:n.kargari@tiau.ac.ir))

**(With the memory of Dr. Farhad Nadim who left us so soon.)**

## **ABSTRACT**

The petroleum industry generates large quantities of oily wastewater that can have detrimental impacts on marine and terrestrial eco-systems. Meanwhile, produced water is referred as the largest waste stream generated in oil and gas industries. Treatment of produced water was the point of attention for past decades, but the degree of treatment has been improved year by the year. While the primary oily water storage pits were obtained to prevent the direct discharge of untreated oily produced water to the environment, the new approaches are trying to treat the stream by the means of different technologies such as membrane or chemical treatment process in such a way that it could be beneficially used or reinjected. However, removing impurities as much possible from produced water is taking the place of the simple expectancy of just removing the oil in new treatment process designs. This paper attempts to have a wide review on the produced water treatment technologies up to the year of 2010 and discusses the new management policies for the treatment of produced water, according to the worldwide regional regulations.

Key Words: Produced water treatment; Oily wastewater treatment; Produced water management; Regional environmental regulations.

# INTRODUCTION

The petroleum industry generates large quantities of oily wastewater that may have detrimental impacts on marine and terrestrial eco-systems. Meanwhile, produced water is referred as the largest waste stream generated in oil and gas industries. The annual cost of disposing of this water was estimated to be 5-10 billion dollars in the US and around 40 billion dollars worldwide during the year of 2002. As the technology of oil and gas production goes forward, new methods are necessary for the efficient handling of produced water to ensure the protection of environment especially littoral regions. Produced water treatment systems generally include a variety of treatment technologies that vary according to feed water composition and proposed end use. The size of the system and volume of oily water effluent also have impact on technology selection [1]. The present article, tries to have a wide review on the produced water treatment technologies up to the year of 2010 and at the end, there will be a discussion on the new management policies for the treatment of produced water according to the worldwide regional regulations.

## PRODUCED WATER TREATMENT TECHNOLOGIES

### 1- Gravity separation

#### 1-1 Retention ponds/Storage pits

Early saltwater wells flowed into retention ponds/storage pits where the undesirable oil was allowed to float and spill over into a nearby creek. Much of the early saltwater drilling and production practices were adapted in the exploitation of crude oil. Storage retention ponds were soon replaced with wooden storage tanks, and petroleum was no longer impounded in open ponds. Water removal capabilities were provided by a closed valve located at the bottom of the wooden tank where the shift operator regularly allowed the separated water to run off into an open creek [2]. Figure 1 shows a retention pond in Kharg Island, Persian Gulf, South of Iran.

#### 1-2 API separator

The most frequently used type of oil-water separator is the API type, which can remove up to 60 to 99% of the free oil in a waste stream. An API separator is a rectangular basin, mostly constructed of concrete, where the separation process takes place by gravity. By creating retention time in the basin, pollutants lighter (oil) and heavier (solids) than water are separated as floating scum (oil) and bottom sludge (sand and other solids). These are subsequently removed by a scraping device for bottom sludge and a device for floating scum removal from the surface [3]. *Figure 2* shows the schematic of an API oil separator.

### **1-3 Skimmer tanks and vessels**

The simplest form of primary treating equipment is a skim (clarifier) tank or vessel; refer to schematic presented in *Figure 3*. These items are normally designed to provide long residence times during which coalescence and gravity separation can occur. Skim tanks can be used as atmospheric tanks, pressure vessels, and surge tanks ahead of other produced water treating equipment. Skim vessels can be either vertical or horizontal in configuration [4].

### **1-4 Disposal piles**

Disposal piles are large-diameter (24- to 48-in.) open-ended pipes attached to the platform and extending below the surface of the water. Their main uses are to: a) concentrate all platform discharges into one location, b) provide a conduit protected from wave action so that discharges can be placed deep enough to prevent sheens from occurring during upset conditions, and c) provide an alarm or shutdown point in the event of a failure that causes oil to flow overboard [4].

### **1-5 Skim piles**

The skim pile is a type of disposal pile. As shown in *Figure 4*, flow through the multiple series of baffle plates creates zones of no flow that reduce the distance a given oil droplet must rise to be separated from the main flow. Once in this zone, there is plenty of time for coalescence and gravity separation. The larger droplets then migrate up the underside of the baffle to an oil collection system. Besides being more efficient than standard disposal piles, from an oil separation standpoint, skim piles have the added benefit of providing for some degree of sand cleaning. Most authorities having jurisdiction state that produced sand must be disposed of without “free oil.” It is doubtful that sand from a vessel drain meets this criterion when disposed of in a standard disposal pile [4].

## **2 - Plate coalescence**

Several different types of devices have been developed to promote the coalescence of small dispersed oil droplets. These devices use gravity separation similar to skimmers but also induce coalescence to improve the separation. Thus, these devices can either match the performance of a skimmer in less space or offer improved performance in the same space. The use of flow through parallel plates to help gravity separation in skim tanks was pioneered in the late 1950s as a method of modifying existing refinery horizontal

rectangular cross-section separators to treat oil droplets less than 150 microns in diameter. Various configurations of plate coalescers have been devised. These are commonly called parallel plate interceptors (PPI), corrugated plate interceptors (CPI), or cross-flow separators. All of these depend on gravity separation to allow the oil droplets to rise to a plate surface where coalescence and capture occur [4]. An oil droplet entering the space between the plates will rise in accordance with Stokes' law. At the same time, the oil droplet will have a forward velocity equal to the bulk water velocity. By solving for the vertical velocity needed by a particle entering at the base of the flow to reach the coalescing plate at the top of the flow, the resulting droplet diameter can be determined. The first form of a plate coalescer was the parallel plate interceptor (PPI), and the most common form of parallel plate interceptor used in production operations is the corrugated plate interceptor (CPI). This is a refinement of the PPI in that it takes up less plan area for the same particle size removal, it makes sediment handling easier, and it has the added benefit of being cheaper than a PPI. *Figure 5* shows the flow pattern of a typical downflow CPI design. In CPIs the parallel plates are corrugated (like roofing material), and the axes of the corrugations are parallel to the direction of flow.

### **3- Enhanced coalescence**

#### **3-1 Free-flow turbulent coalescers**

Free-flow turbulent coalescers are a type of device that is installed inside or just upstream of any skim tank or coalescer to promote coalescence. These devices had been marketed and sold under the trade name SP Packs. They are no longer available for sale but the concept can still be employed in water treating system design. As shown in *Figure 6*, SP Packs force the water flow to follow a serpentine pipe-like path sized to create turbulence of sufficient magnitude to promote coalescence, but not so great as to shear the oil droplets below a specified size. SP Packs are designed to coalesce oil droplets to a defined drop size distribution, with a  $d_{\max}$  of 1,000 Microns [4].

#### **3-2 Pre-coalescers**

Several new technologies that are available and are emerging into the mainstream produced water treatment industry are pre-coalescers. These are often included in pipe or treatment processes upstream of gravity type or centrifugal separation technologies and operate by increasing the overall oil droplet size. Increase sizing makes it easier to remove oil in a subsequent downstream process. These devices are usually composed of numerous fine polyethylene strands packed in close proximity to each other. The strands provide high surface area contact within the flowing produced water and attract small oil particles and aid in their coalescence until they are too large to be held by the media, at

which point they are released back into the process stream. Two common examples of these technologies are explained in following parts [5].

### **3-2-1 PECT-F**

The Performance Enhancing Coalescence Technology (PECT) range is a technology concept unique to Cyclotech Company. The first commercialized technology in this range is the PECT-F®, denoting a Fiber based coalescer concept. Cyclotech developed the PECT-F® technology to achieve a significant improvement in separation efficiency of Produced Water Deoiling Hydrocyclone systems. The PECT-F® is a media based coalescer which is installed as a cartridge assembly into either the inlet chamber of the Deoiling Hydrocyclone vessel or into a bespoke vessel located upstream of the PWT system. The inlet chamber of a typical conventional Deoiling Hydrocyclone is the largest chamber in the vessel and has a residence time of up to 20 seconds. The PECT-F® uses this residence time constructively to achieve partial oil droplet coalescence to capture and grow droplets from a size that would not be separated by the Deoiling hydrocyclone to a size that can be separated. The PECT-F® technology is targeted at:

- existing systems which do not meet current legal or stretch targets of performance, or require excessive chemical dosing to do so;
- new-build systems where the application of Deoiling Hydrocyclones is potentially marginal due to difficult fluid characteristics [6].

*Figure 7* shows a conventional deoiling hydrocyclone equipped with the PECT technology [7].

### **3-2-2 Mare's Tail**

Tulloch (2003) [8] reviews a pre-coalescer device that consists of a bundle of oleophilic polypropylene fibers inside a cartridge positioned along a flow line just upstream of another separation device (e.g., hydrocyclone, filter). The fibers serve to aggregate small oil droplets for easier downstream removal. The coalescence occurs rapidly (within two seconds). The appearance of the fiber bundle looks somewhat like the tail of a horse, giving rise to the device's name "Mare's Tail." Tulloch (2003) [8] reports that oil droplet growth was enhanced by increasing either the length of the fibers or the number of fibers packed into the cartridge. *Figure 8* demonstrates the principle of operation of Mare's Tail pre-coalescer.

## **4- Enhanced gravity separation**

By applying an artificial gravitational field, particle settling velocities can be greatly enhanced and the effective size range over which efficient separations can be achieved

can be extended to much smaller sizes. The additional force will permit efficient separations to be achieved even at very fine particle sizes. In order to take advantage of the efficiency improvements that may be realized by using artificial gravitational fields, new generations of enhanced gravity separators have been developed and placed into commercial production in the oil processing industry. The two main categories of these technologies are described in the following sections.

#### **4-1 Hydrocyclones**

Static oil-water separators, usually referred as hydrocyclones, induce a centrifugal rotating motion to the produced water to amplify the effect of gravity by several orders of magnitude to separate the oil from the water. Oily water enters tangentially through the inlet into a cylindrical chamber. The rotating motion of the water is accelerated through the concentric reducing and taper sections of the hydrocyclone. The centrifugal forces cause the oil droplets to move to the core of the vortex where axial flow reversal occurs and the coalesced reject stream is recovered. The clean water moves to the outside of the hydrocyclone and is discharged. Total residence time of the liquid in the hydrocyclone is only 2-3 seconds [9]. Hydrocyclones can provide significant savings in weight, space, and power usage. Hydrocyclones are particularly effective where system operating pressures are high. If system pressures are low, booster pumps are required to increase the operating pressure for the hydrocyclone. This however induces a shearing action on the oil droplets and will reduce overall system efficiency. Hydrocyclones also require relatively high and constant flow rates. If flow rates are low or variable, a recycle flow stream through a surge tank can be added [10]. As shown in *Figure 9*, the liner consists of the following four sections: a cylindrical swirl chamber, a concentric reducing section, a fine tapered section, and a cylindrical tail section [4].

#### **4-2 Centrifuges**

As shown in *Figure 10*, a centrifuge system sometimes referred as dynamic hydrocyclone consists of a rotating cylinder, axial inlet and outlet, reject nozzle, and external motor. An external motor is used to rotate the outer shell of the hydrocyclone. The rotation of the cylinder creates a “free vortex.” The tangential speed is inversely proportional to the distance to the centerline of the cyclone. Since there is no complex geometry that requires a high pressure drop, dynamic units can operate at lower inlet pressures (approximately 50 psig) than static hydrocyclone units. In addition, the effect of the reject ratio is not as important in dynamic units as it is in static units. Centrifuges have found few applications relative to hydrocyclones because of poor cost–benefit ratio [4].

### **4-3 Ctour process**

The CTour Process AS company has the commercial rights to the CTour technology. The CTour technology is a liquid-liquid extraction process. In this process, a liquid condensate is used to extract liquid for the dissolved components in produced water. The condensate also helps remove dispersed oil by coalescing with small oil droplets. The CTour process includes the following steps:

- C Harvest a suitable condensate stream from production;
- C Inject condensate in liquid form into the produced water stream;
- C Mix and disperse the condensate into the water;
- C Allow for adequate contact time between condensate and water;
- C Separate the contaminated condensate from the water in a separation process
- Cycle the condensate, containing contaminants, back to the production stream.

Field trials have been performed on the Ctour process. The process can remove approximately 70 percent of dispersed oil and PAHs, as well as up to 70 percent of most phenols [11] A flow diagram of Ctour processes is given in *Figure 11*.

### **5- Adsorption/Filtration**

When the aim is to actually remove an oily phase from a continuous contaminated water stream through filtration, absorbing media is normally used. Many compounds can be used as absorbent/filter material with the most important properties being having hydrophobic-oleophilic characteristics. Absorbents are generally classified into two categories, those that cannot be regenerated and those that can [12]. The method is usually used when the inlet oil concentration to the system is low (<10 ppm) [5]. Filter beds could be categorized to synthetic and natural medias. Synthetic fibers are used as bed material, including polypropylene, polyester and polyamide (nylon), often causing environmental issues at the end of their use due to their non-biodegradable characteristics. Natural, environmentally friendlier alternatives have emerged too, such as agricultural products like woven or non-woven cotton, wool and kenaf [12] and activated carbon. Other studies have investigated the applicability of peat, reed canary grass, flax, hemp fibre, Salvinia, wood chip, rice husk, coconut husk and bagasse [13]. As many of these are waste products from agriculture, they are inexpensive and natural. Their efficiency differs widely, however but a general rule can be observed dictating that increased hydrophobicity, oil droplet size and bed depth in general can be expected to improve oil removal [12]. Some proven and available commercially used material/techniques are:

- Nutshell filter/Walnutshell filters
- Sand filters
- Multi-media filter
- Organolclay

- Total oil remediation and recovery (TORR)
- Symons Adsorption media (SAM)
- Cetco's polishing system
- Kapok filter
- MYCLEX
- Micro porous polymer extraction (MPPE)
- Activated carbon
- Zeolite

A schematic representation of a typical MPPE unit is shown in 15.

## **6- Flotation separation**

Gas flotation units work by introducing small gas bubbles into the wastewater being treated. The gas bubbles acquire a small electronic charge, opposite that of the oil droplets. As the gas bubbles rise through the oily wastewater, oil attaches to the bubbles [4,9]. Flotation units use two distinct methods for producing small gas/air bubbles needed to contact with water: *pressurized gas/air injection* and *induced gas/air* [14].

### **6-1- Pressurized gas/air injection**

In this method, gas/air is feed to the stream by usually an external gas/air compressor. The more applied commercial systems are:

- Gas sparging system
- Dissolved gas/air flotation (DGF/DAF)
- Gas liquid reactors (GLRs) or Microbubble flotation (MBF)

### **6-2- Induced gas/air**

In induced gas/air units, gas bubbles are introduced into the stream either by the use of a hydraulic inductor/eductor device or by a vortex set up by mechanical rotors/pumps. There are many different proprietary designs of induced gas units. All require a means to generate gas bubbles of favorable size and distribution into the flow stream, a two-phase mixing region that causes a collision to occur between the gas bubbles and the oil droplets, a flotation or separation region that allows the gas bubbles to rise to the surface, and a means to skim the oily froth from the surface. Some of the most commercially accepted methods are:

- **Induced gas /air flotation (IGF/IAF)**
  - Hydraulic eductor gas induction units
  - Mechanical induced gas flotation units
- **Gas inducing pumps**

- DGF pumps
- ONYXTM micro-bubble pumps
- **Tank based flotation**

## **7- Membrane filtration**

Membrane filtration is a technology which has been developed in the past 2 decades for water and waste water treatment. Membrane filtration systems can be categorized in micro filtration (MF), ultra filtration (UF), nano filtration (NF) and reverse osmosis (RO). Micro filtration membranes have a relatively large pores, UF and NF separate smaller particles and RO is capable of removing dissolved matter (salts). MF and UF are applied in waste water treatment (though not very frequent) and NF is very rarely applied. RO is applied for production of drinking water or boiler feed water and unfit for waste water treatment unless extensive pre-treatment (MF and/or UF) is applied. Membranes are manufactured of various materials, mostly polymers such as cellulose, nylon, PTFE, but membranes can also be made of ceramics. Membranes are manufactured in various configurations, such as hollow fibre, tubular or spiral wound membranes, which are fitted in membrane modules. Membranes produce a permeate (or cleaned water) and a retentate (in which the pollution is concentrated). The retentate, which may still contain 98 - 99% water, must be disposed of. Depending on the type of membranes and the composition of the waste water, the retentate of a micro-filtration or ultra-filtration unit may constitute 5 - 10% of the waste water flow rate. Whereas membrane filtration is capable of achieving an effluent oil concentration of 5 ppm or less, it should be noted that membranes so far have not been used widely in heavy duty applications such as the treatment of produced water and the development of membranes for these applications is still under research. Special chemically modified ceramic membranes for the treatment of oil-in-water emulsions might replace the present commercial system within the next five years. Membrane systems suffer from fouling problems and show a poor long term stability of water flux. Membranes must be replaced every 3 - 5 years [15].

Bilstad and Espedal [16] compared MF and UF membranes in pilot trial to treat the North Sea oilfield-produced water. Results showed that UF, but not MF, could meet effluent standards for total hydrocarbons, SS, and dissolved constituents. By UF membrane treatment with molecular weight cut-off (MWCO) was between 100,000 and 200,000 Da, total hydrocarbon concentration could be reduced to 2 mg/L from 50 mg/L (96% removal). Benzene, toluene, and xylene (BTX) were reduced by 54%, and some heavy metals like Cu, and Zn were removed to the extent of 95%. Lee and Frankiewicz [17] tested a hydrophilic UF membrane of 0.01- $\mu$ m pore size, in crossflow mode to treat oilfield-produced water. A hydrocyclone was first used to desand and de-oil the wastewater. The hydrocyclone pretreated the raw produced water removing solids and oil content by 73% and 54%, respectively. O&G concentration after UF could be reduced to

less than 2mg/L. The preferred feed-water specification for ideal performance of UF was oil and solids less than 50 and 15 ppm, respectively. Low-pressure-driven membranes for MF of membrane pore size between 0.1 and 5\_μm or UF with membrane pore size less than 0.1\_μm or a combination of MF/UF polymeric or ceramic membranes are suitable for removing oil content of oilfield-produced water. However, ceramic membranes are preferred over delicate polymeric membranes because the former have a better tolerance to high temperature, high oil content, foulants, and strong cleaning agents [17]. Ceramic ultra- and NF-membranes are a relatively new class of materials for the treatment of produced water [18,19]. Tested performance of ceramic crossflow MFs to separate oil, grease, and SS from produced water. Permeate quality of dispersed O&G was 5 mg/L and of SS was less than 1mg/L. Combined membrane pretreatment and RO technology are effective methods for produced water treatment [20]. Xu et al. [21] investigated a two-stage laboratory-scale membrane to treat gas field produced water generated from sandstone aquifers. They studied ultra-low-pressure RO and NF membranes to meet quality standards for potable and irrigation water, and iodide concentration in brine.

## **8- Electrodialysis (ED)**

Dissolved salts in water are cations and anions. These ions can attach to electrodes with an opposite charge. In ED, membranes are placed between a pair of electrodes. The membranes allow either cations or anions to pass through [22]. This method is suitable for produced water reclamation with low TDS concentrations. Recent results indicate that this approach may be appropriate for reclamation of produced waters with relatively low TDS loads but is unlikely to be cost-effective for treatment of concentrated produced waters [23].

## **9- Freeze-thaw/evaporation**

Crystal Solutions, LLC, a joint venture of Gas Technology Institute (formerly Gas Research Institute) and BC Technologies used freeze-thaw/evaporation (FTE) technology to treat produced water. The FTE is a process that used naturally occurring temperature swings to alternately freeze and thaw produced water, concentrating the dissolved solids and creating relatively large volumes of clean water suitable for various beneficial uses [24,25].

## **10- Biological treatment**

Biological treatment is one process that could be used for removal of organic material. The major limitation of any biological treatment system is that long retention periods (hours to days are desirable) are required for the biological degradation process to occur. An offshore facility with significant water production would require very large storage

capacity with commensurately high loads that quickly make such an offshore installation impractical [10].

## **MANAGEMENT OF PRODUCED WATER**

Before start to decide about the treatment of produced water, we should answer some fundamental questions:

- What is the final purpose treatment: reuse, reinjection, surface or underground disposal?

The method of treatment and the quality of treated produced water so much differs when it is suppose for being used as for example fire water, irrigation or underground well injection.

- In which part of the world are we leaving?

That is important since you can dispose the stream with the oil content of up to 42 mg/l into the Gulf of Mexico while the amount decreases up to 15 mg/l oil content for machinery drainage in the Persian Gulf for produced water as the region is a closed aquatic region and should be protected more.

- Where the produced water is originated from?

Coal bed methane (CBM) produced water is usually more acidic than the oilfield produced water. And also the volatile components concentrations are lower in accordance with gas field produced waters.

- Could we minimize the volume of oil in the produced water?

In many cases we can reduce the oil content by controlling the upstream vessels such as desalters or separators. In many cases the control process could be automated and for example a drain valve could be signaled closed by the oil in water sensor. Continuous oil in produced water monitoring benefits the growth of unmanned production facilities, and need to monitor the purity of re-injection water.

Treatment method is not just a single equipment and usually the experience of the designer and the regional regulations should compose the suitable arrangement for the best design and operation.

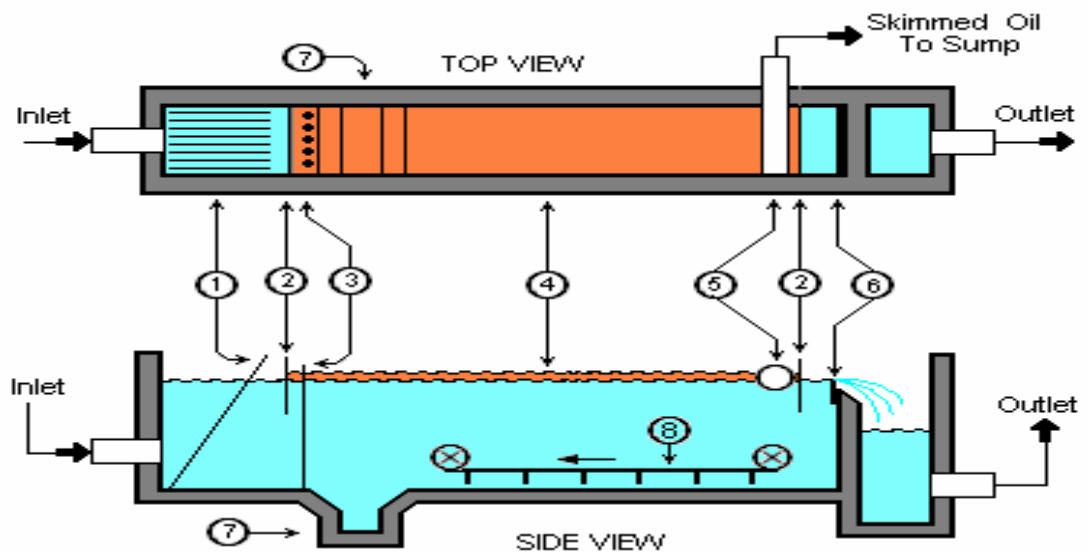
## **CONCLUSION**

Treatment of produced water could be categorized in ten major processes which every one itself could be divided in subcategories. The selection of a process for the treatment is so much dependent on the characteristics of the produced water quality and its origin and also the final purpose of its use after the treatment. Regional regulations are also a key parameter to arrange the extent of the treatment. New devices such as online oil in

water monitors could inhibit the presence of oil both in upstream and downstream of the treatment plant.

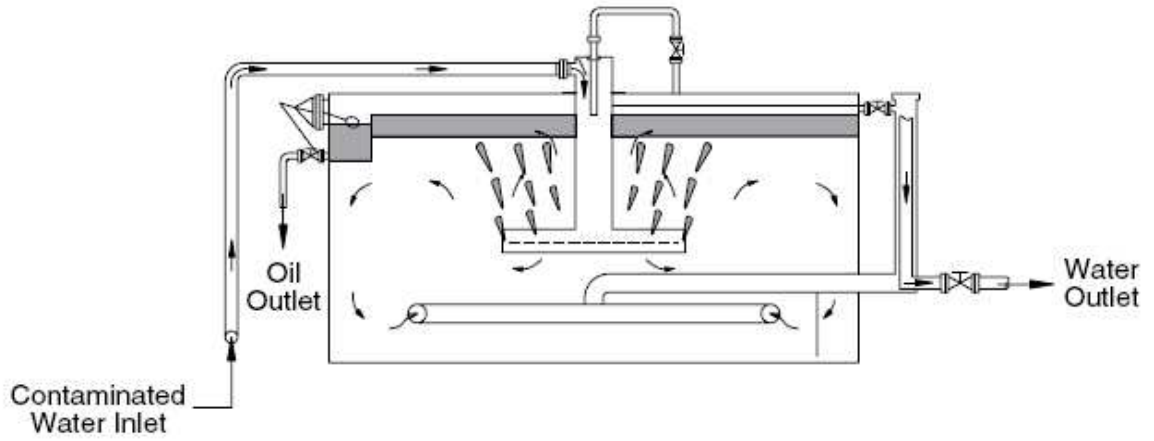


**Figure 1.** Retention pond for oil-water separation, Kharg Island, Persian Gulf, South of Iran

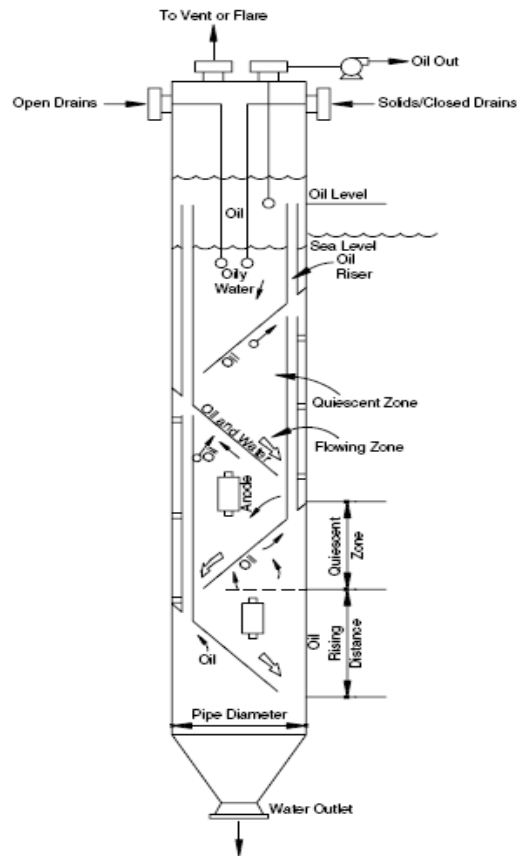


- 1 Trash trap (inclined rods)
- 2 Oil retention baffles
- 3 Flow distributors (vertical rods)
- 4 Oil layer
- 5 Slotted pipe skimmer
- 6 Adjustable overflow weir
- 7 Sludge sump
- 8 Chain and flight scraper

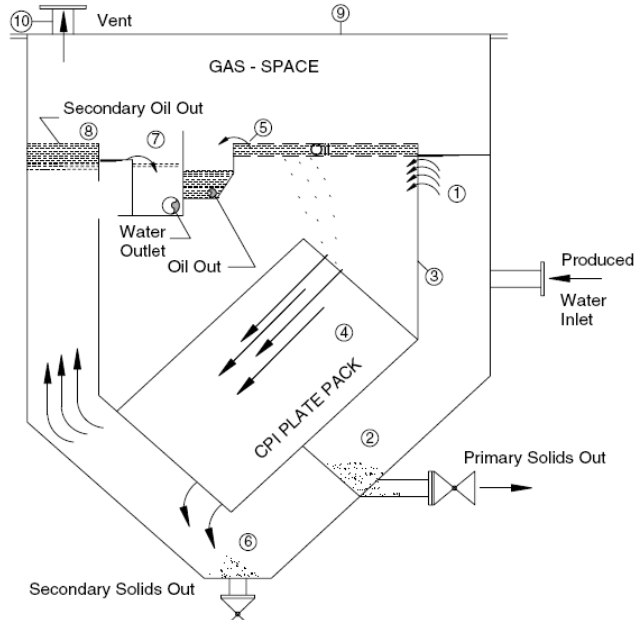
**Figure 2.** Schematic of an API oil separator [26]



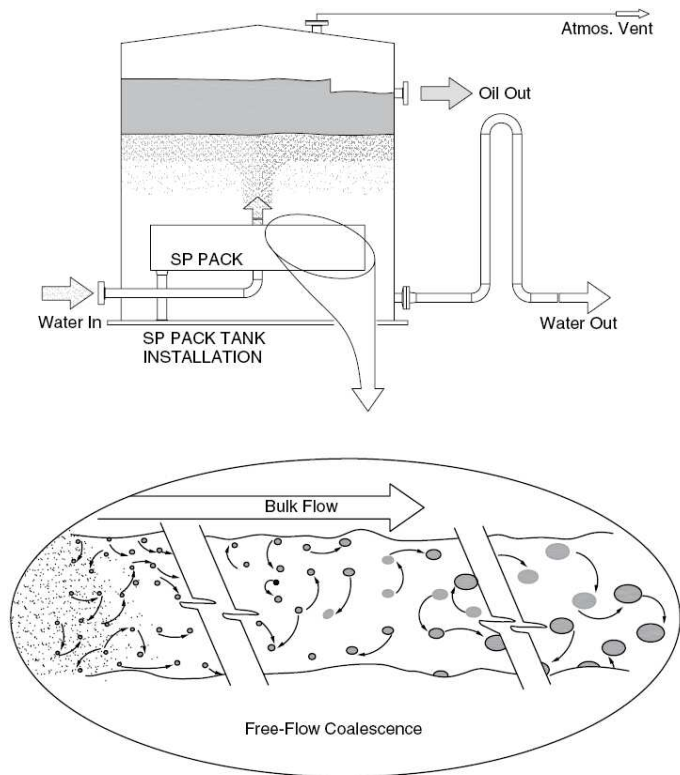
**Figure 3.** Schematic of a skimmer tank [4]



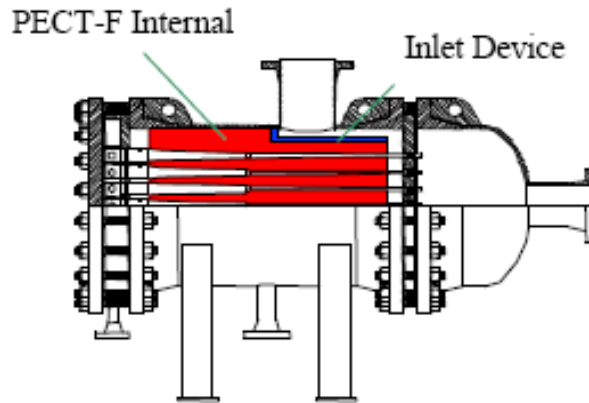
**Figure 4.** Cross section showing flow pattern of a skim pile [4]



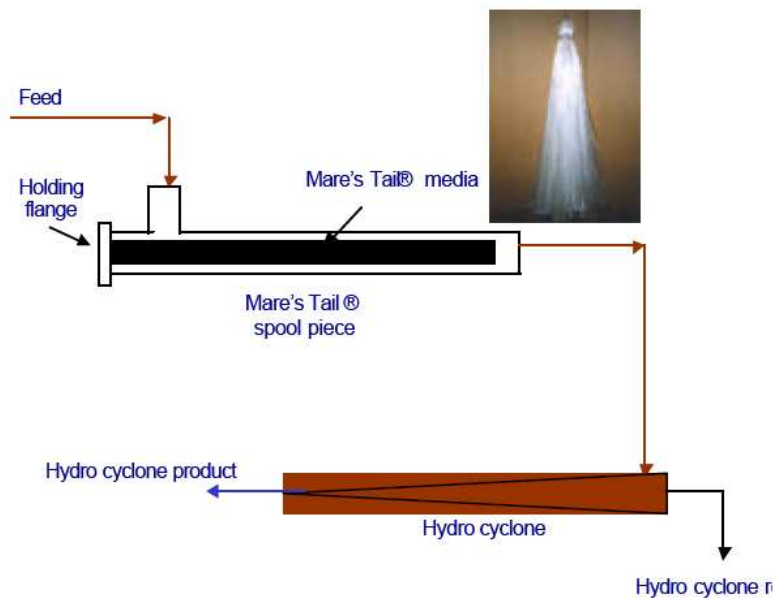
**Figure 5.** Schematic showing flow pattern of a typical down-flow CPI design [4]



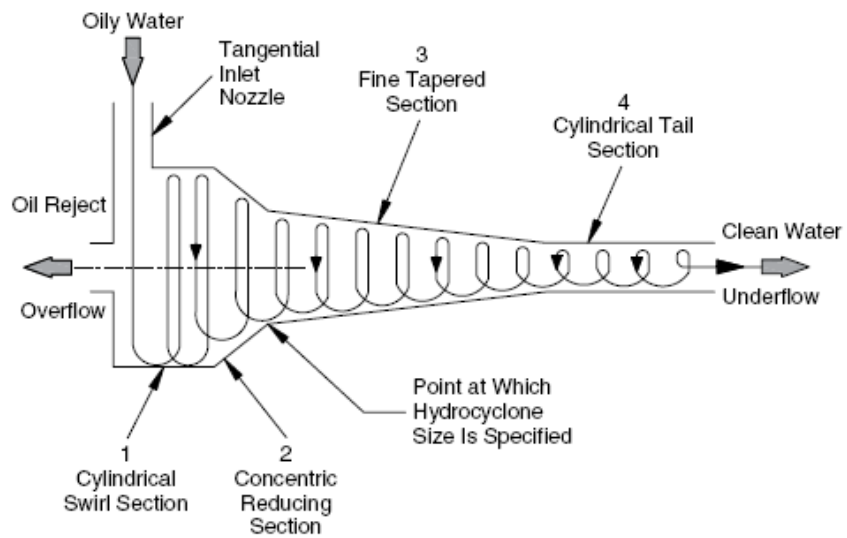
**Figure 6.** Principles of operation of an SP Pack [4]



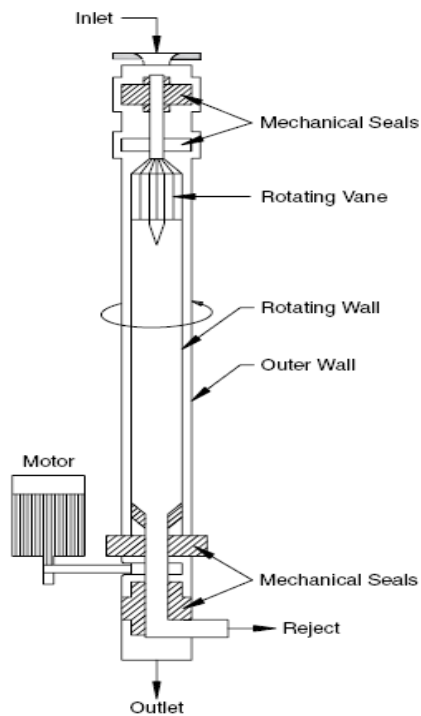
**Figure 7.** Conventional deoiling hydrocyclone vessel equipped with PECT technology [7]



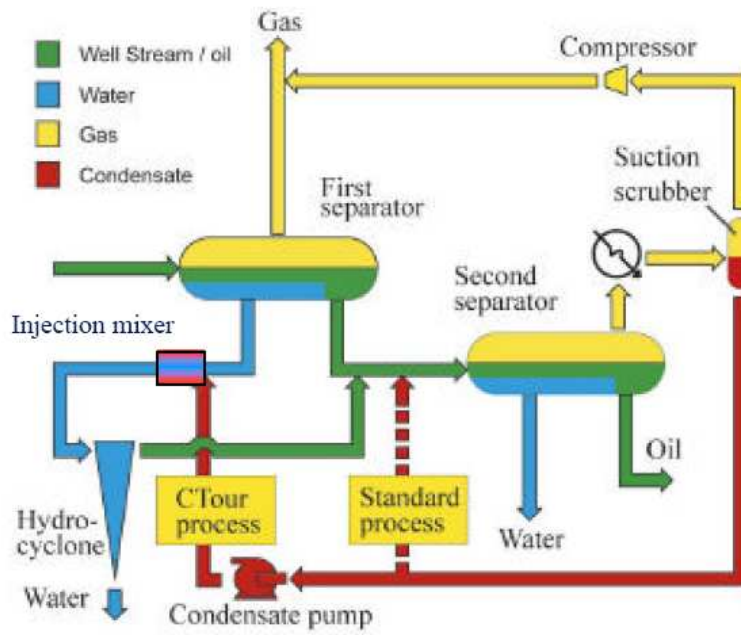
**Figure 8.** Principle of operation of Mare's Tail [11]



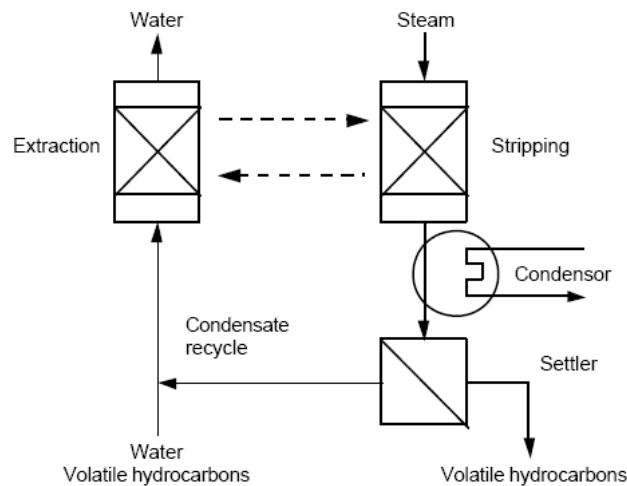
**Figure 9.** Principles of operation of a hydrocyclone: 1) cylindrical swirl chamber 2)concentric reducing section 3) fine tapered section 4) a cylindrical tail section [4]



**Figure 10.** Centrifuge system for oil-water separation [4]



**Figure 11.** Flow diagram of the CTour process [11]



**Figure 12.** MPPE extraction/ stripping system [27]

## REFERENCES CITED

1. Fossil Water Corporation, 2007.Scopping study: Produced Water Beneficial Re-Use-High TDS Waters.
2. Delgado, A., Lee, H.M., Brown & Root, "the chronology of water – oil Handling Equipment". Presented at the International Petroleum Conference and Exhibition of exico, Villahermosa, Mexico, March 3 – 5 (1998).
3. American Petroleum Institute (API), 1990. Monographs on Refinery Environmental Control -Management of Water Discharges (Design and Operation of Oil-Water Separators).Publication 421, First Edition.
4. Arnold, K.E. Stewart, M., 2008. Surface production operations-Design of Oil Handling Systems and Facilities, vol. 1, third ed., Gulf Publishing Co, Houston, Texas.
5. Owens,N. and Lee,D.W.,2007.The use of micro bubble flotation technology in secondary & tertiary produced water treatment - A technical comparison with other separation technologies.TUV NEL,5<sup>th</sup> Produced Water Workshop Aberdeen,Scotland,30<sup>th</sup>-31<sup>st</sup> May 2007.
6. Cyclotech catalogue, 2009.PECT-F® Pre-coalescer for a Deoiling Hydrocyclone.  
[http://www.cyclotech.com/Products/PECT\\_F%AE/Debottlenecking/](http://www.cyclotech.com/Products/PECT_F%AE/Debottlenecking/)
7. Sinker, A.B., Humphris, M., Wayth, N., 1999.Enhanced deoiling hydrocyclone performance without resorting to chemicals. Paper SPE 56969, presented at the offshore Europe Conference held in Aberdeen September 1999.
8. Tulloch, S.J., 2003. "Development & Field Use of the Mare's Tail® Pre-Coalescer," presented at the Produced Water Workshop, Aberdeen, Scotland, March 26-27.
9. Bradley,B.W.,1990.Produced water treatment technology assessment. Prepared for the American Petroleum Institute-Offshore effluent guidelines steering committee, Washington,DC,December 1990.

10. CAPP, 2001. Produced water waste management, Technical report, Canadian Association of Petroleum Products (CAPP), page 9.
11. Knudsen, B.L., Hjelsvold, M., Frost, T.K., Svarstad, M.B.E., Grini, P.G., Willumsen, C.F., Torvik, H. 2004. Meeting the zero discharge challenge for produced water. paper SPE 86671, presented at the seventh SPE International Conference on Health, Safety, and Environment in Oil and Gas Exploration and Production held in Calgary, Alberta, Canada, 29–31 March 2004.
12. Glimmerman, E.D., 2006. Assessment of the available technologies for slop and bilge water treatment and monitoring offshore. Master's Thesis, Chalmers University of Technology, Goteborg, Sweden.
13. Ribeiro T, Rubio J & Smith R 2003, ' A Dried Hydrophobic Aquaphyte as an Oil Filter for Oil/Water Emulsions', Spill Science & Technology Bulletin, Vol. 8, Nos. 5–6, pp. 483–489.
14. Cline, J.T., 2000. Survey of gas flotation technologies for treatment of oil & grease. Presented at the 10<sup>th</sup> produced water seminar, Houston, TX, Jan. 19–21.
15. REMPEC (Regional Marine Pollution Emergency Response Centre for the Mediterranean Sea) and Euro-Med Partnership, 2004. Port reception facilities for collecting ship-generated garbage, bilge waters and oily wastes. Activity B, TEBO D IN Consulting & Engineers. Project MED.B4.4100.97.0415.8
16. Bilstad, T., Espedal, E., 1996. Membrane separation of produced water, Water Sci. Technol. 34, pp. 239–246.
17. Bader, M.S.H, 2007. Seawater versus produced water in oil-fields water injection operations, Desalination 208 ,159-168.
18. Shams Ashaghi, K., Ebrahimi, M., Czermak, P., 2007. Ceramic ultra- and nanofiltration membranes for oilfield produced water treatment: a mini review, Open Environ. J. 1 (2007) 1–8.
19. Chen, A.S.C., Flynn, J.T. , Cook, R.G. , Casaday, A.L., 1991. Removal of oil, grease, and suspended solids from produced water with ceramic crossflow microfiltration, SPE Prod. Eng. 6 (1991) 131–136.

20. Burnett, D.B., 2004. Potential for Beneficial Use of Oil and Gas Produced Water, <http://www.rrc.state.tx.us/commissioners/williams/environment/beneficialuses.pdf>.
21. Xu, P., Drewes, J.E., Heil, D., 2008. Beneficial use of co-produced water through membrane treatment: technical-economic assessment, *Desalination* 225, pp.139–155.
22. Arthur, J.D., Langhus, B.G., Patel, C., 2005. Technical summary of oil and gas produced water treatment technologies, [http://www.rrc.state.tx.us/commissioners/williams/environment/produced\\_water\\_treatment\\_Tech.pdf](http://www.rrc.state.tx.us/commissioners/williams/environment/produced_water_treatment_Tech.pdf)
23. Dallbauman, L., Sirivedhin, T., 2005. Reclamation of produced water for beneficial use, *Sep. Sci. Technol.* 40, pp185–200.
24. Lang, K., 2000. Managing produced water, [http://www.pttc.org/technology\\_summaries/statev6no4.htm](http://www.pttc.org/technology_summaries/statev6no4.htm)
25. Sorensen, J.A., Boysen, J., Boysen, D., Larson, T., 2002. Field Application of the Freeze / Thaw Evaporation (FTE®) Process for the Treatment of Natural Gas Produced Water in Wyoming, <http://www.osti.gov/servlets/purl/791058-6iLoKQ/native>, 2002.
26. [http://en.wikipedia.org/wiki/API\\_oil-water\\_separator](http://en.wikipedia.org/wiki/API_oil-water_separator)
27. Pars, H.M. and Meijer, D.Th. 1998. Removal of dissolved hydrocarbons from production water by Macro Porous Polymer Extraction (MPPE). Paper SPE 46577, presented at the 1998 SPE International Conference on Health, Safety and Environment in Oil and Gas Exploration and Production held in Caracas, Venezuela, 7–10 June 1998.